THE METROPOLITAN MUSEUM OF ART

◆ THE LOWER DANUBE: MEDIEVAL TO MODERN ◆

Vienna to Bucharest Aboard M.S. Royal Crown



Travel with THE MET



◆ June 10 to 21, 2016 ◆

THE METROPOLITAN MUSEUM OF ART

Dear Members and Friends of The Metropolitan Museum of Art,

The Lower Danube flows across the heart of Central Europe, passing through less-visited countries including Slovakia, Hungary, Serbia, Bulgaria, and Romania. Next June, join us aboard the luxurious *Royal Crown* for a 10-night cruise from Vienna to Bucharest. Accompanying us on this voyage is Jayson Kerr Dobney, Associate Curator and Administrator in the Department of Musical Instruments.

Call at Bratislava and Budapest to tour dazzling palaces. Watch an equestrian demonstration in Kalocsa, Hungary, and in lively Belgrade, Serbia, tour the city's landmarks. Cruise through the Iron Gates, where the Danube narrows as it winds through a series of magnificent cliff-lined gorges. In Vidin, Bulgaria, explore the fortress of Baba Vida and attend a special concert at the opera house. Visit the attractive city of Veliko Tarnovo, the former capital of Bulgaria. Conclude in Bucharest to tour the immense Palace of Parliament and the Village Museum. An optional prelude in Vienna and postlude in Romania are offered.

We hope to welcome you aboard this delightful voyage, in the company of members of the National Trust for Historic Preservation, Yale Educational Travel, and the Harvard Alumni Association.

Sincerely,



Nina McN. Diefenbach
*Vice President for
Institutional Advancement*

TRAVELING WITH YOU



Jayson Kerr Dobney has been an Associate Curator in the Department of Musical Instruments since 2007. He was the curator for the exhibitions *Early American Guitars* (2014), *The Sau-Wing Lam Collection*

of Rare Italian Stringed Instruments (2012), and *Guitar Heroes* (2011), and collaborated on *Painting Music in the Age of Caravaggio* (2015) and *Watteau, Music, and Theater* (2009). Jayson has authored many publications on stringed and percussion instruments and is a classically trained pianist and organist. ♦

TRAVEL HIGHLIGHTS

- ♦ Stunning palaces in Bratislava, Slovakia, and Budapest, Hungary
- ♦ A pipe organ concert and an equestrian demonstration in Kalocsa, Hungary, known for its paprika production and colorful embroidered folk art
- ♦ A private concert in Vidin's opera house and other special performances on board and ashore, including folk music and the monk's choir in Arbanasi, Bulgaria
- ♦ A full day of cruising through the spectacular Iron Gates
- ♦ Visits to exceptional museums, historic synagogues, and medieval fortresses



ONE MET.
MANY WORLDS.



◆ THE LOWER DANUBE: MEDIEVAL TO MODERN ◆

Vienna to Bucharest Aboard M.S. Royal Crown

June 10 to 21, 2016



Bratislava, Slovakia

NEW YORK

Friday, June 10

Depart New York on an overnight flight to Vienna.

VIENNA, AUSTRIA

Saturday, June 11

Arrive in Vienna, elegant city of music and the arts on the Danube. Admire the Art Nouveau architecture before lunch at a famed Viennese coffee house. In the afternoon, board *M.S. Royal Crown*, our luxurious riverboat. Enjoy an onboard performance by local musicians and toast our upcoming cruise with a glass of champagne or Austrian wine.

VIENNA

Sunday, June 12

Discover the treasures of the Habsburg Empire on a tour of the Kunsthistorisches Museum. Highlights of the collection include paintings by Pieter Bruegel the Elder, Rembrandt, and Caravaggio, and the fine pieces of the Kunstkammer. The museum also houses an impressive collection of musical instruments. Following lunch on board, the afternoon is free to stroll in the charming city center or visit another of its fine museums. Attend the captain's welcome dinner before *Royal Crown* departs this evening.

BRATISLAVA, SLOVAKIA

Monday, June 13

Arrive this morning in Bratislava, situated in the foothills of the Carpathian Mountains. Drive by Pálffy Palace, where a six-year-old Mozart gave a concert, and see the stunningly restored Mirbach Palace during a walking tour. There will be time to browse in the tempting crafts shops before returning to the ship for lunch and an afternoon cruise to Budapest. Gather for a lecture at teatime. Dinner is on board.



Domes of St. Sava, Belgrade

BUDAPEST, HUNGARY

Tuesday, June 14

Spend the morning in Buda, on the west bank of the Danube. On Castle Hill, see the grand Royal Palace and the neo-Gothic church of St. Matthias, built in the 13th century and decorated with beautiful Zsolnay ceramic tiles. This afternoon, walk in the bustling Central Market Hall, built at the end of the 19th century, and visit the Jewish Synagogue. The second-largest active synagogue in the world, it is noteworthy for the Romantic, Moorish, and Byzantine elements in its design. Alternatively, drive to Memento Park, where statues from the Communist era have been turned into a sculpture park. A traditional gypsy band will perform for us after dinner.



KALOCSA, HUNGARY

Wednesday, June 15

Step ashore in Kalocsa, best known for its paprika and colorful embroidered folk art. During a morning tour, learn about the importance of paprika to this area and visit the cathedral to hear the magnificent pipe organ, first played by Franz Liszt. We will also see the treasures of the Archbishop's Library and attend a special equestrian demonstration before returning to the ship. An afternoon lecture will prepare us for upcoming visits.

BELGRADE, SERBIA

Thursday, June 16

Arrive in Belgrade, capital of Serbia and a lively city of museums and galleries, food and music, and eclectic architecture. Tour landmarks including the Kalemegdan Fortress and the Serbian Orthodox Temple of St. Sava. Stop at the tomb of Marshal Tito and view highlights of the vast collection of the National Museum. Rejoin *Royal Crown* for lunch. In the afternoon, visit the Ethnographic Museum, featuring traditional regional dress and folk art, and speak with an artist about the contemporary art scene. Following dinner, enjoy a performance of folk music.

CRUISING THROUGH THE IRON GATES

Friday, June 17

Relax during a full day of cruising through one of Europe's most awe-inspiring natural wonders, the Iron Gates. Here the Danube narrows as it winds through a series of magnificent cliff-lined gorges between Serbia and Romania, a result of the river working its way through the mountains over thousands of years. Attend presentations on the music and history of this region.

VIDIN, BULGARIA

Saturday, June 18

In Vidin, explore the fortress of Baba Vida, built by the Bulgars in the 10th century and the only entirely preserved medieval castle in the country. Continue with an architectural tour of the city's Orthodox cathedral, synagogue, and Renaissance buildings, followed by a private concert in the opera house. Alternatively, drive to Belogradchik in the foothills of the Balkan Mountains to see the unique rock formations and prehistoric cave paintings in the nearby Magura Cave. Lunch is on board. As we cruise down the Danube, attend a lecture at teatime.

SVISHTOV ♦ ROUSSE, BULGARIA

Sunday, June 19

Depart from Svishtov for Veliko Tarnovo, an intellectual center and Bulgaria's former capital, built into the steep hills overlooking the Yantra River. See impressive Tsarevets Fortress, and stroll past workshops where craftsmen use both ancient and modern techniques for woodcarving, ceramics, and metalwork. Sample local wines during lunch in nearby Arbanasi, known for its rich history. Continue to the Nativity Church to admire its icons and hear the monks' choir. Rejoin *Royal Crown* in Rousse this evening.



photo © colorstime

Rock sculpture of Decebalus, Iron Gates

GIURGIU ♦ BUCHAREST, ROMANIA

Monday, June 20

Today discover Bucharest, Romania's handsome capital. Tour the immense Palace of Parliament, commissioned by former dictator Nicolae Ceausescu, which dominates the city. After a lunch of local specialties, visit the lovely domed Atheneum, home of the philharmonic, or explore the Village Museum, a gathering of houses from all parts of Romania located in a pleasant park. Toast a memorable trip at our farewell dinner aboard *Royal Crown* this evening.

BUCHAREST ♦ NEW YORK

Tuesday, June 21

Disembark and transfer to the Bucharest Airport for flights home. ♦

M.S. ROYAL CROWN ♦ DECK PLAN

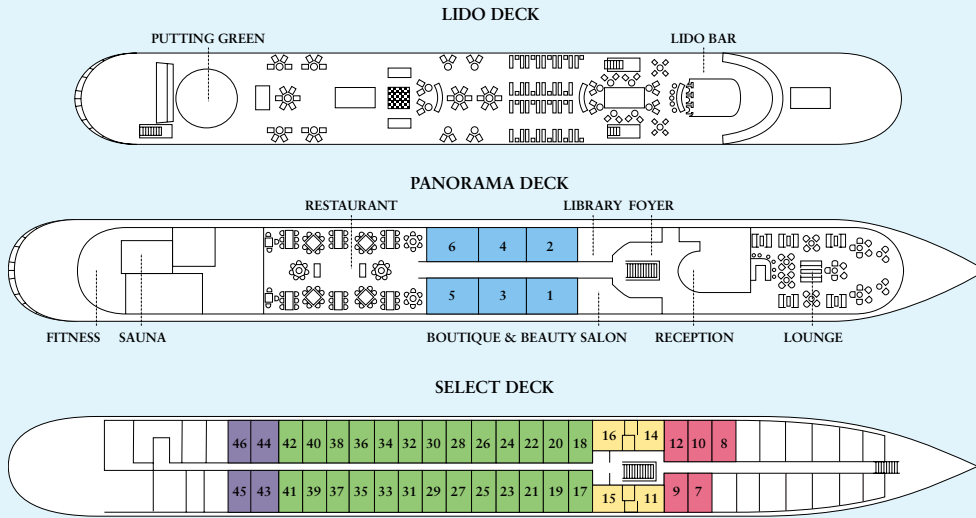

M.S. Royal Crown (left) and Premium Suite (right)

Refurbished in 2010, the intimate *Royal Crown* offers a 1930s-inspired Art Deco style and a comfortable, relaxed atmosphere. Specially designed for cruising the rivers of Europe, *Royal Crown* has a spacious sun deck and a lounge with panoramic views. Suites on Select Deck have portholes, and the Royal Suites on Panorama Deck have large windows. All 45 suites feature rosewood wardrobes, satellite TV and radio, a safety deposit box, individually controlled air conditioning, and bathrooms with shower. Onboard amenities include a library with daily newspapers, wi-fi throughout the ship, boutique, fitness area, sauna with shower facilities, and a restaurant with open seating.

CRUISE RATES (per person, double occupancy)

Cabins	Decks	Rates
Cabins 43 to 46 Junior Suites.	Select Deck	\$5,995
Cabins 17 to 42 Deluxe Suites.	Select Deck	\$7,495
Cabins 7, 8, 9, 10 & 12 Superior Suites.	Select Deck	\$9,995
Cabins 11, 14, 15 & 16 Premium Suites.	Select Deck	\$10,995
Cabins 1 to 6 Royal Suites.	Panorama Deck	\$14,995

A limited number of cabins are available for single occupancy at a supplement of 30 to 100% of the cruise rate.

RATES INCLUDE

- ♦ Ten nights cabin accommodations aboard *Royal Crown*, including all port charges
- ♦ All meals on the cruise; complimentary wine with lunch and dinner
- ♦ Sightseeing via private motorcoach as per itinerary
- ♦ Entrance fees for all included visits
- ♦ Airport / pier / airport group transfers for those on suggested flights
- ♦ Taxes, service and portorage; gratuities to local guides and drivers; customary shipboard gratuities

NOT INCLUDED IN RATES International airfare; passport fees; alcoholic beverages other than wine at lunches and dinners; personal items and expenses; airport transfers for those not on suggested group flights; baggage in excess of one suitcase; optional prelude and optional postlude; trip insurance; any other items not specifically mentioned as included.

THE METROPOLITAN MUSEUM OF ART

The Lower Danube: Medieval to Modern ♦ June 10 to 21, 2016 RESERVATION APPLICATION

To reserve a place, please return this form along with your deposit of \$2,500 per person (of which \$350 is non-refundable for administrative fees) payable to *Academic Arrangements Abroad*, 1040 Avenue of the Americas, 23rd Floor, New York, NY 10018-3721.

Names in Full as on Passports. Please Print.

Address

City State Zip

Telephone (Home) (Business)

Fax E-mail

ACCOMMODATIONS

Royal Crown Cabin Preference (1) (2)

I wish to share a cabin with

OPTIONAL PRELUDE & OPTIONAL POSTLUDE

- I/We wish to join the optional prelude in Vienna (\$1,790 per person; single supplement \$465)
- I/We wish to join the optional postlude in Romania (\$1,120 per person; single supplement \$240)

Hotel Room Preference Double Twin Single

FORM OF PAYMENT

- Enclosed is my check (payable to *Academic Arrangements Abroad*)
- Credit card (may be used for deposit only)

Name on Credit Card

Credit Card Number

3- or 4-Digit Security Code Expiration Date

Each participant must sign below. I/We confirm that I/we have carefully read and agree to the *Terms & Conditions* of this Program. I/We agree to full payment by check or wire transfer 120 days prior to departure.

Signature (Required) Date

Signature (Required) Date

For additional information, please contact *Academic Arrangements Abroad*

Telephone: 212-514-8921 or 800-221-1944 ♦ Fax: 212-344-7493 ♦ E-mail: met@arrangementsabroad.com ♦ www.metmuseum.org/travel

OPTIONAL PRELUDE IN VIENNA JUNE 7 to 11, 2016

During a three-night stay in Vienna, experience the rich music, arts, and architecture that make the city a perennial cultural capital. Visit Mozart's former home, now a museum dedicated to him, and the Rococo summer palace of the Habsburgs where he performed as a child. At the Spanish Riding School, see the famed Lipizzaner stallions and take a private tour of the stables. Admire Art Nouveau buildings such as the golden-domed Secession Museum and Otto Wagner's modernist Postal Savings Bank. Discover works by Schiele, Munch, and Klimt at the Upper Belvedere, and enjoy free time to independently explore other museum collections. We will also attend a musical performance at one of the city's lovely venues. And no trip to Vienna would be complete without sampling the delicious cuisine, including the iconic Sacher torte. ♦

PRELUDE RATE \$1,790 per person. Single supplement \$465. Includes three nights at Steigenberger Hotel Herrenhof, Vienna; breakfast daily, two lunches, and one dinner; sightseeing as noted.



Lipizzaner stallions, Vienna

Photo © American Tourist Board

OPTIONAL POSTLUDE IN ROMANIA June 21 to 24, 2016

Spend three days among the charming towns and rolling hills of the Romanian countryside. In Sinaia visit Peles Castle, the former summer residence of the royal family, before a tasting of the local sparkling wine. Stay two nights in the medieval fortified city of Brasov, surrounded by the Southern Carpathian Mountains. From there, we will explore Sighisoara, a UNESCO World Heritage gem founded by Transylvanian Saxons in the 12th century, and see the impressive fortified church in Biertan. Return to Bucharest to view paintings by European masters, sculptures by Brancusi, and Romanian art dating from medieval times to the present at the National Museum of Art. ♦

POSTLUDE RATE \$1,120 per person. Single supplement \$240. Includes two nights at the Aro Palace in Brasov, one night at Athenee Palace Hilton Bucharest; breakfast daily, two lunches, and three dinners; sightseeing as noted.

♦ TERMS & CONDITIONS ♦

AIRFARE Academic Arrangements Abroad (AAA) will be pleased to assist with air travel arrangements for this program, including specially negotiated group airfare when available, suggested group flights, or your own individual requests, for a processing fee of \$40 per person. Complete details will be provided in your confirmation mailing.

PAYMENT SCHEDULE A deposit of \$2,500 per person, payable to *Academic Arrangements Abroad*, of which \$350 is non-refundable for administrative fees, is required with the reservation application. Final payment, by check or wire transfer, must be received 120 days prior to departure.

HEALTH All participants must be in good health. This program involves extensive walking over uneven surfaces and climbing stairs at monuments and other locations not handicapped accessible, and climbing in and out of various conveyances. Any condition that may require assistance or special medical attention must be reported at the time of your reservation. Please note: *Royal Crown* does not have an elevator.

PHOTOGRAPHY Photographs or, in some cases, videotapes of participants of Travel with the Met trips may be used for educational and promotional purposes by The Metropolitan Museum of Art.

INSURANCE TRIP CANCELLATION / EMERGENCY MEDICAL EVACUATION / BAGGAGE / ACCIDENT AND SICKNESS INSURANCE IS STRONGLY RECOMMENDED. CANCELLATION PENALTIES ARE STRICTLY ENFORCED. AAA will send an insurance application upon receipt of deposit, although you may select an alternative insurer of your choice.

CHANGES IN ITINERARY & COSTS The itinerary is subject to change at the discretion of The Metropolitan Museum of Art (the Met) and AAA. All prices quoted are based on prevailing fuel prices, airfares, and currency exchange rates in effect as of the time of brochure printing and are subject to change without notice. Deviations from the scheduled itinerary are at the expense of the individual.

RESPONSIBILITY CLAUSE The participation of the Met is limited to educational sponsorship of the program described in this brochure (The Program). AAA acts only as an agent for the participant with respect to transportation, accommodations, and all other services, relating to The Program. AAA, the Met and/or their agents assume no responsibility or liability for any act, error, or omission, or for any injury, loss, accident, delay, or irregularity which may be occasioned by reason of any defect in any aircraft, ship, train, bus, or other carrier, or through neglect or default of any subcontractor or other third party, which may be used wholly or in part in the performance of their duty to the participants of The Program. The passage ticket issued by the carrier is the sole contract between the participant and the carrier. Nor will AAA or the Met and/or their agents be responsible for loss, injury, damages, or expenses to persons or property, due to illness, weather, strikes, local laws, hostilities, wars, terrorist acts, acts of nature, or other such causes in connection with The Program or anything beyond their reasonable control. AAA is not responsible for transportation or other program delays and changes, nor additional expenses or loss of time that may be incurred. In the event it becomes necessary or advisable for the comfort or well-being of the participants, or for any reason whatsoever, to alter the itinerary at any time, without notice to the participants, such alterations will be made without penalty to AAA or the Met. Additional expenses, if any, shall be borne by the participants. Baggage and personal effects are the sole responsibility of the participant at all times. AAA and the Met reserve the right to accept or decline any person as a participant at any time, or to require any participant to withdraw from The Program at their own expense when such an action is determined by AAA or the Met to be in the best interest of the participant's health and safety, or the general welfare of the other participants.

CANCELLATION POLICY AAA must strictly adhere to its cancellation policy to offset costs incurred prior to the commencement of The Program, which may include but are not limited to: advance payments to land operators; ship charters; communication expenses; development/promotional expenses, and the loss of time that might have permitted resale of reserved space. All cancellations must be made in writing to the offices of AAA and are subject to a \$350 non-refundable administrative fee. All refunds are limited to amounts actually received by AAA and are the sole responsibility of AAA; the Met shall have no liability for refunds. At the time AAA receives written notification of cancellation, the following cancellation charges will apply: cancellations received between 120 to 91 days prior to departure, 20 percent of the program cost per person; those received between 90 and 61 days prior to departure, 50 percent of the program cost per person; no refunds will be given for cancellations received within 60 days of departure. No refunds are given for cancellation on or after the day of departure, or for unused portions of the tour, for any reason. Air cancellation charges, if any, will be assessed in accordance with airline regulations. All group fare tickets must be issued no less than 30 days prior to departure. NOTE: Neither AAA nor the Met shall be liable for any airline cancellation penalties incurred by the purchase of a non-refundable ticket. In the case of a cancellation due to shortage of participants, AAA will attempt to notify all participants at least 45 days prior to departure. However, AAA reserves the right to cancel The Program prior to departure for any reason and, in such case, reimbursement of refundable costs of the trip by AAA shall constitute full settlement with the participant. In the unlikely event that a dispute arises between a participant and AAA or the Met, the following conditions will apply: (a) the dispute will be settled by binding arbitration administered by the American Arbitration Association in New York, NY; (b) the dispute will be governed by New York Law; (c) the maximum amount of recovery to which a participant shall be entitled under any and all circumstances will be the sum of all monies actually received from the participant by AAA. The participant agrees that this is a fair and reasonable limitation on the damages, of any sort whatsoever, that a participant may suffer. Upon payment of the deposit to AAA, the participant agrees to be bound by the above terms and conditions.

Copyright © 2015 Arrangements Abroad, Inc.

CST 2059789-40



Academic Arrangements Abroad

On the front and back covers: Royal Residence, Ofen [Buda], (Königliche Burg in Ofen) by Josef Diveky (Hungarian, 1887–1951). 1909. Color lithograph. The Metropolitan Museum of Art. (WW.267). On the back cover: Kunsthistorisches Museum, Vienna

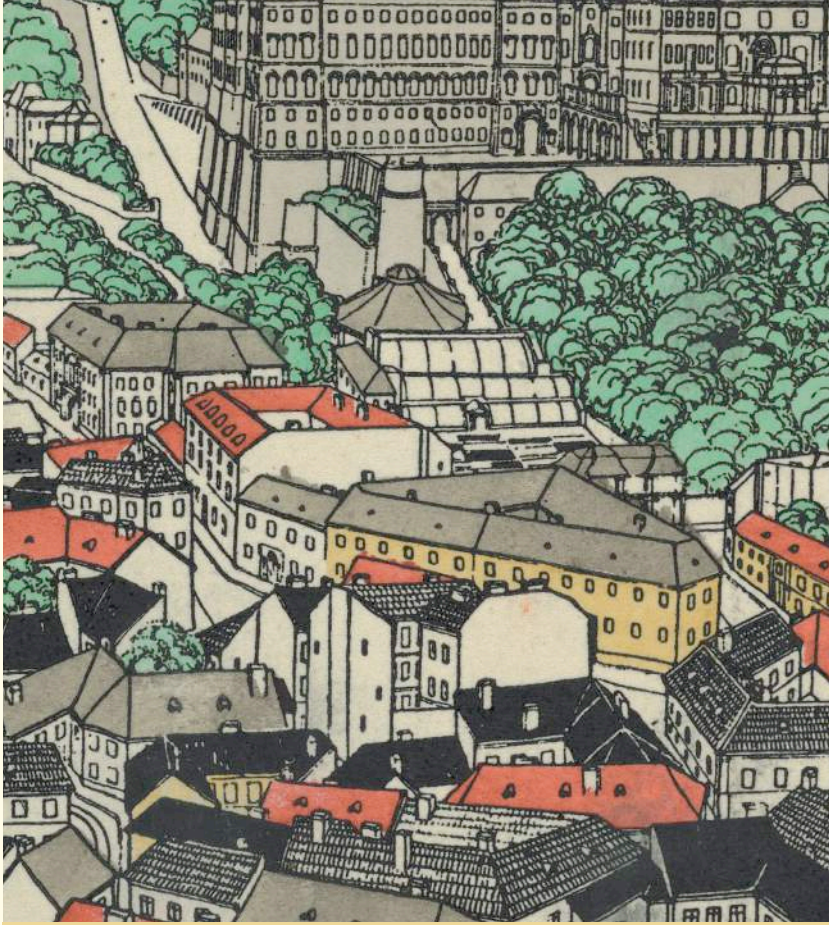

THE METROPOLITAN MUSEUM OF ART

1000 Fifth Avenue • New York, NY 10028

• THE LOWER DANUBE: MEDIEVAL TO MODERN •
Vienna to Bucharest Aboard M.S. Royal Crown • June 10 to 21, 2016



Travel with THE MET
www.metmuseum.org/travel